

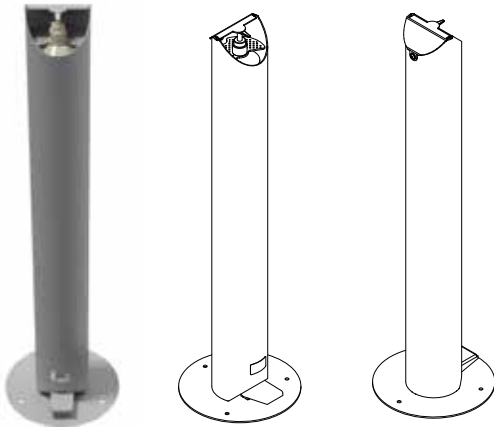

# ZEN310 - ZENITH FOOT PEDAL SANITISER

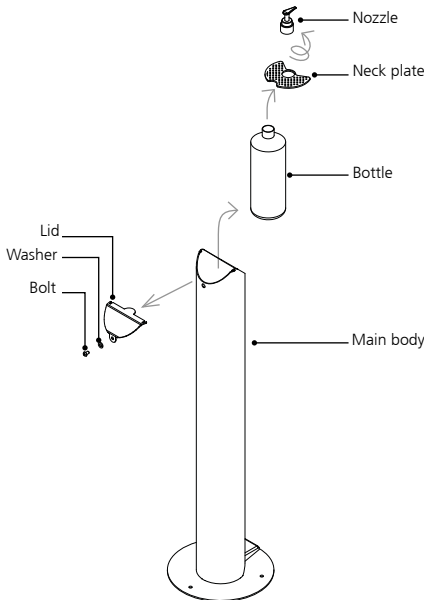

**Fig. 1:** Bottle replacement:



**Fig. 2:** Height adjustment

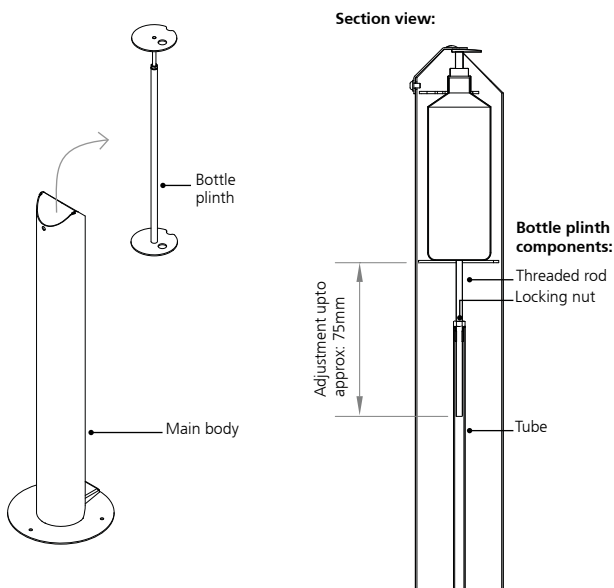

## Description:

The Zenith hand sanitiser dispenser is foot-pedal operated so there is no-hand contact at all, minimising the risk of contamination. It is also 100% mechanical, so there are no-battery requirements, meaning it is cheaper in the long run and better for the environment. Built for public areas - such as workplaces, retail areas and public realm - the Zenith hand sanitiser dispenser is both practical and beautiful. Made from stainless steel it is also strong and durable.

## Product Dimensions:

Diameter 115mm post, 900mm high. Round base plate 250mm. Adjustable height inside for different sized sanitiser bottles

## Material and Finish:

Stainless steel grade 304, satin polished finish.

## Fixing method:

Free standing.

The product can be fixed to ground using M8 ground anchors (not supplied).

## Delivery details:

Weight: 6kg

Box dimensions: 950 x 260 x 260mm

Pack includes one assembled post, 2 no. bottles 1no. nozzle & 1 no. cap

## Usage:

Place hands under nozzle and press the foot pedal to dispense the sanitiser.

## Replacing the bottle:

- Undo fixing bolt of lid with 4mm Allen Key, remove lid of dispenser and bottle as shown on **fig.1**
- Refill bottle and insert it back in place. Alternatively, swap bottle for new one placing the neck plate on before screwing the nozzle.
- Slot lid back on dispenser and secure it using the allen key, making sure the nozzle sits under the protrusion on the lid.

## Adjustable height for different sanitiser bottles:

- Remove lid and bottle as above and extract the bottle plinth as shown in **fig. 2**
- Adjust the height by loosening the locking nut and twisting threaded rod to the desired height.
- Once the correct height is reached, tighten the locking nut and slide back inside the main body.
- Place new bottle in place and ensure neck plate is fitted and the nozzle sits under the protrusion on the lid.

## Maintenance:

In order to maintain a 'factory finish', stainless steel may require an ongoing cleaning regime, the extent and frequency of which depends on the environment in which the product is placed. Wipe down the product with water and detergent, or specialist cleaning agents if deposits are embedded.



# ZEN310-PPC - ZENITH FOOT PEDAL SANITISER

## Description:

The Zenith hand sanitiser dispenser is foot-pedal operated so there is no hand contact at all, minimising the risk of contamination. It is also 100% mechanical, so there are no-battery requirements, meaning it is cheaper in the long run and better for the environment. Built for public areas - such as workplaces, retail areas and public realm - the Zenith hand sanitiser dispenser is both practical and beautiful. Made from mild steel and polyester powder coated with stainless steel footpedal and lid: it is strong and durable.

## Product Dimensions:

Diameter 115mm post, 900mm high. Round base plate 250mm. Adjustable height inside for different sized sanitiser bottles

## Material and Finish:

Main body: Mild steel polyester powder coated  
Lid and Footpedal: Stainless steel grade 304, satin polished finish.

## Colour Options (semi gloss finish):

RAL9005:  Black  
RAL7016:  Anthracite

## Fixing method:

Free standing.  
The product can be fixed to ground using M8 ground anchors (not supplied).

## Delivery details:

Weight: 6kg  
Box dimensions: 950 x 260 x 260mm  
Pack includes one assembled post, 2 no. bottles 1no. nozzle & 1 no. cap

## Usage:

Place hands under nozzle and press the foot pedal to dispense the sanitiser.

## Replacing the bottle:

- Undo fixing bolt of lid with 4mm Allen Key, remove lid of dispenser and bottle as shown on **fig.1**
- Refill bottle and insert it back in place. Alternatively, swap bottle for new one placing the neck plate on before screwing the nozzle.
- Slot lid back on dispenser and secure it using the allen key, making sure the nozzle sits under the protrusion on the lid.

## Adjustable height for different sanitiser bottles:

- Remove lid and bottle as above and extract the bottle plinth as shown in **fig. 2**
- Adjust the height by loosening the locking nut and twisting threaded rod to the desired height.
- Once the correct height is reached, tighten the locking nut and slide back inside the main body.
- Place new bottle in place and ensure neck plate is fitted and the nozzle sits under the protrusion on the lid

## Maintenance:

In order to maintain a 'factory finish', All components will require an ongoing cleaning regime, the extent and frequency of which depends on the environment in which the product is placed. Wipe down the product with water and detergent, or specialist cleaning agents if deposits are embedded.

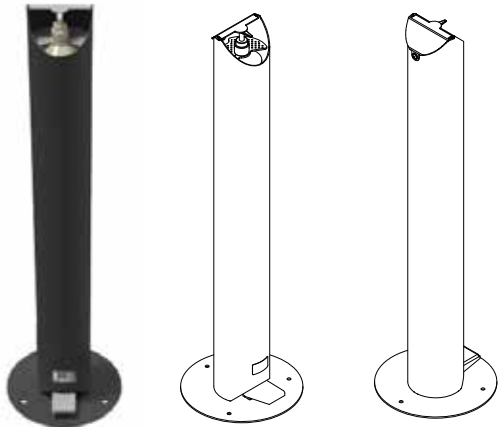

Fig. 1: Bottle replacement:

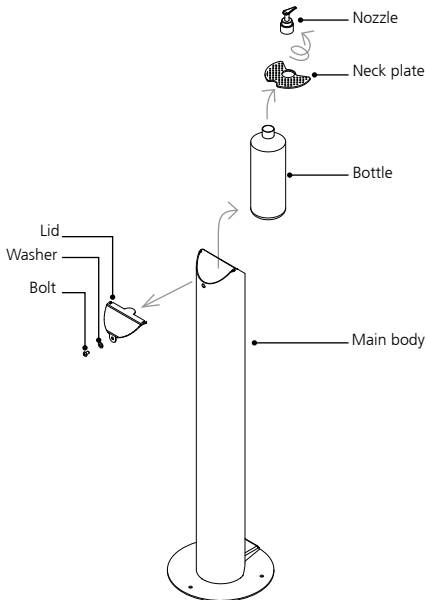
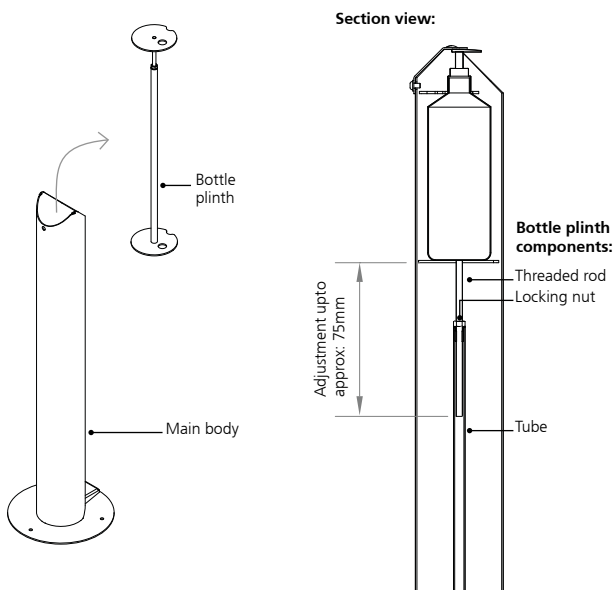

Fig. 2: Height adjustment





# ZEN310-PPC-KIDS - ZENITH FOOT PEDAL SANITISER FOR KIDS



Fig. 1: Bottle replacement:

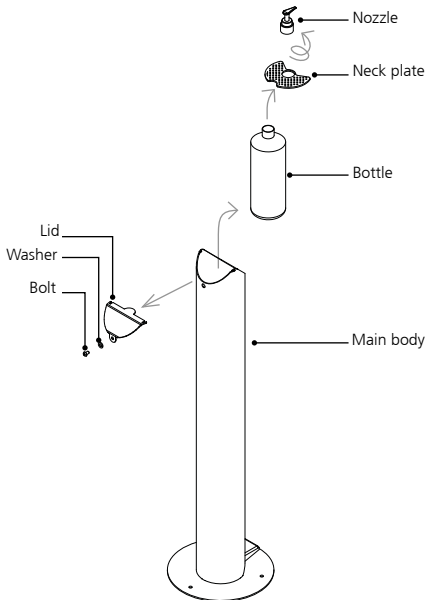
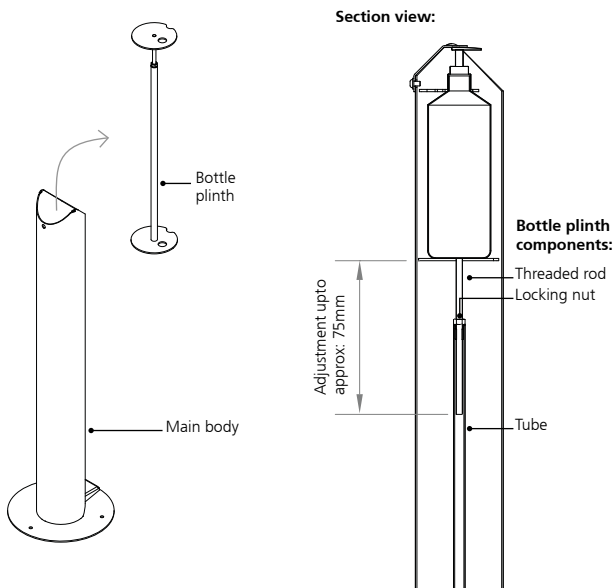

Fig. 2: Height adjustment



## Description:

The Zenith hand sanitiser dispenser for kids is foot-pedal operated so there is no-hand contact at all, minimising the risk of contamination. It is also 100% mechanical, so there are no-battery requirements, meaning it is cheaper in the long run and better for the environment. The kids version of our sanitiser dispenser is built with children in mind. Shorter than our standard size, but robust to withstand maximum usage. Ideal for schools and public areas - the Zenith hand sanitiser dispenser for kids is both practical and beautiful. Made from mild steel and polyester powder coated with stainless steel footpedal and lid: it is strong and durable.

## Product Dimensions:

Diameter 115mm post, 800mm high. Round base plate 250mm. Adjustable height inside for different sized sanitiser bottles

## Material and Finish:

Main body: Mild steel polyester powder coated  
Lid and Footpedal: Stainless steel grade 304, satin polished finish.

## Colour Options (semi gloss finish):

RAL1018: Zinc yellow  RAL3020: Signal red  RAL6018: Green  RAL5015: Sky Blue 

## Fixing method:

Free standing.  
The product can be fixed to ground using M8 ground anchors (not supplied).

## Delivery details:

Weight: 6kg  
Box dimensions: 950 x 260 x 260mm  
Pack includes one assembled post, 2 no. bottles 1no. nozzle & 1 no. cap

## Usage:

Place hands under nozzle and press the foot pedal to dispense the sanitiser.

## Replacing the bottle:

- Undo fixing bolt of lid with 4mm Allen Key, remove lid of dispenser and bottle as shown on **fig.1**
- Refill bottle and insert it back in place. Alternatively, swap bottle for new one placing the neck plate on before screwing the nozzle.
- Slot lid back on dispenser and secure it using the allen key, making sure the nozzle sits under the protrusion on the lid.

## Adjustable height for different sanitiser bottles:

- Remove lid and bottle as above and extract the bottle plinth as shown in **fig. 2**
- Adjust the height by loosening the locking nut and twisting threaded rod to the desired height.
- Once the correct height is reached, tighten the locking nut and slide back inside the main body.
- Place new bottle in place and ensure neck plate is fitted and the nozzle sits under the protrusion on the lid.

## Maintenance:

In order to maintain a 'factory finish', All components will require an ongoing cleaning regime, the extent and frequency of which depends on the environment in which the product is placed. Wipe down the product with water and detergent, or specialist cleaning agents if deposits are embedded.